

Reinhold Environmental Ltd.



***2007 APC Round Table & Expo
Presentation***

***July 8-10, 2007
Chattanooga, TN
Hosted by TVA***

High Frequency Switched Mode Power Supplies

- Where We've Been
- Where We Are
- Where We're Going

Where We've Been



SIR Oliver Lodge

+



Cat Fur

=



TR Sets

Sir Oliver Lodge Pioneered the Application of
Rectified DC Using Rotating Cat Fur
In the Early 1900's.

This was the Precursor to The TR Sets
Used on the Vast Majority of
Electrostatic Precipitators Used Today

Power Supply Evolution



- Early Rotating Mechanical Rectifiers
- Vacuum Tube Rectifiers
- Saturable Core Reactor & TR Set Systems
- SCR/Thyristor & TR Set Systems
- High Energy Pulser Systems
- Switched Mode Power Supplies & Hybrid IGBT Systems

Conventional TR Set Status



- Still Widely Used on Existing & **New** ESP's
- Outputs >80 kV @ 3000 mA although Still Typically Lower
- Generally Perceived as Highest Reliability Device
- Have Seen Price Increases due to Copper, Steel & Oil

HF Power Supply History - Suppliers

- Alstom First Unit (SIR) in Service circa 1993
- NWL First Unit (PowerPlus) in Service circa 1999
- Siemens First Unit (PIC410F) in Service circa 1992

How They Work

Thyristor (SCR) Based

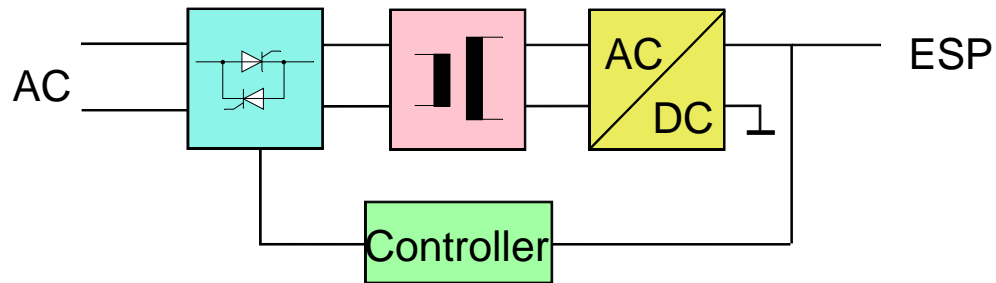

HF SMPS

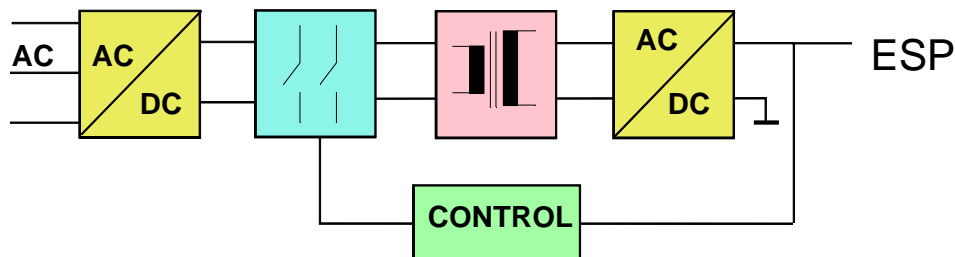

Or...

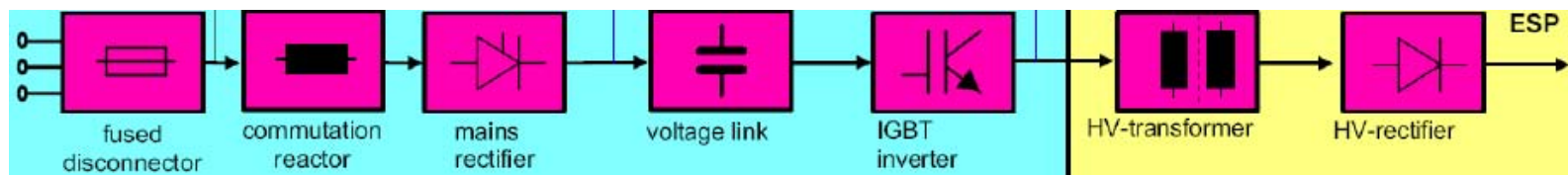

How They Work, cont.

Hybrid

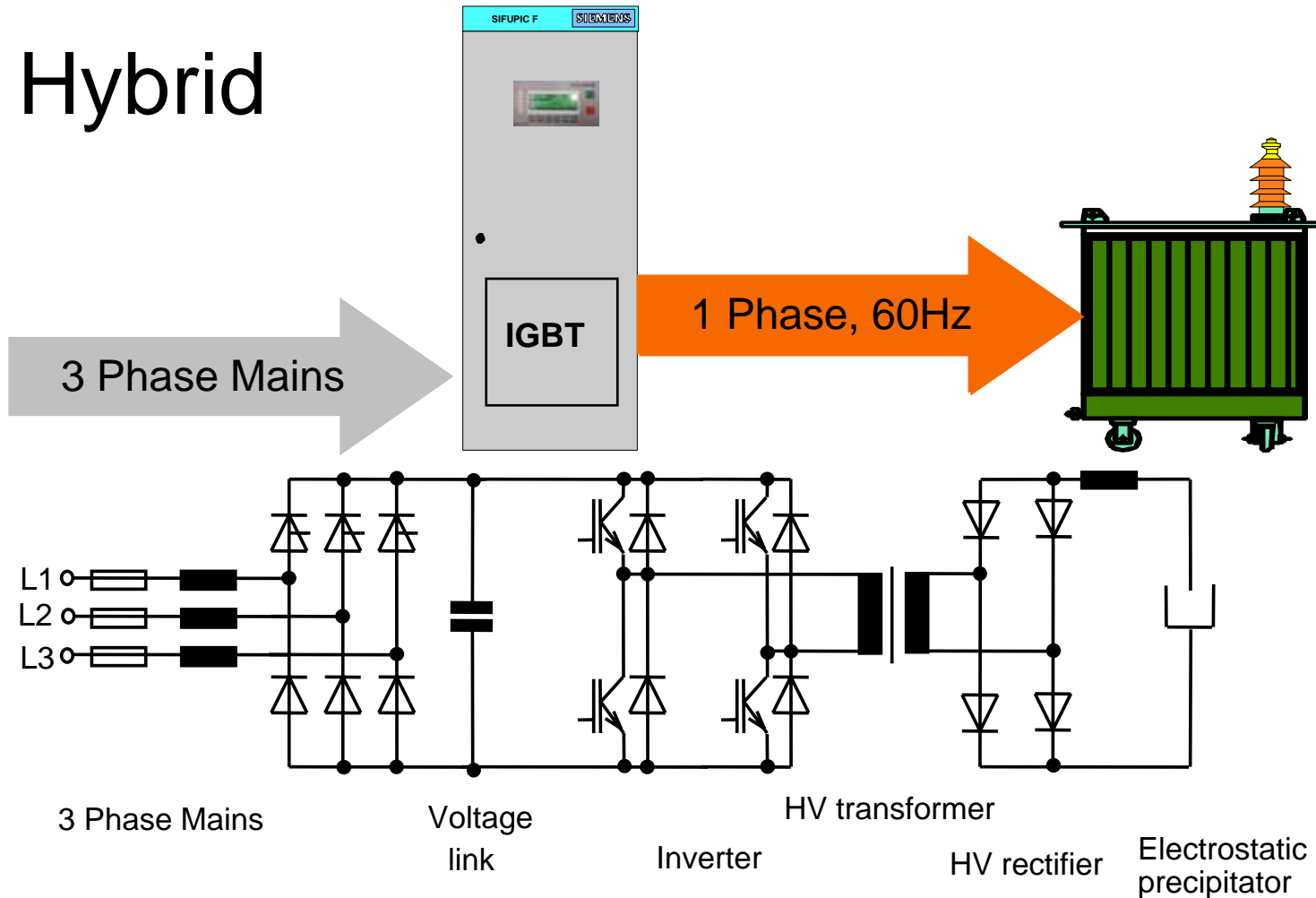

What's The Result?

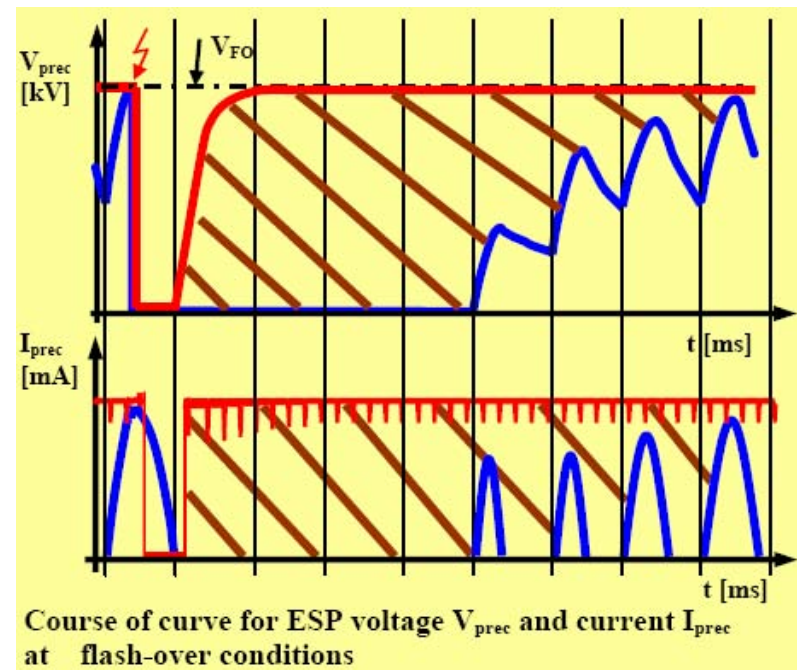
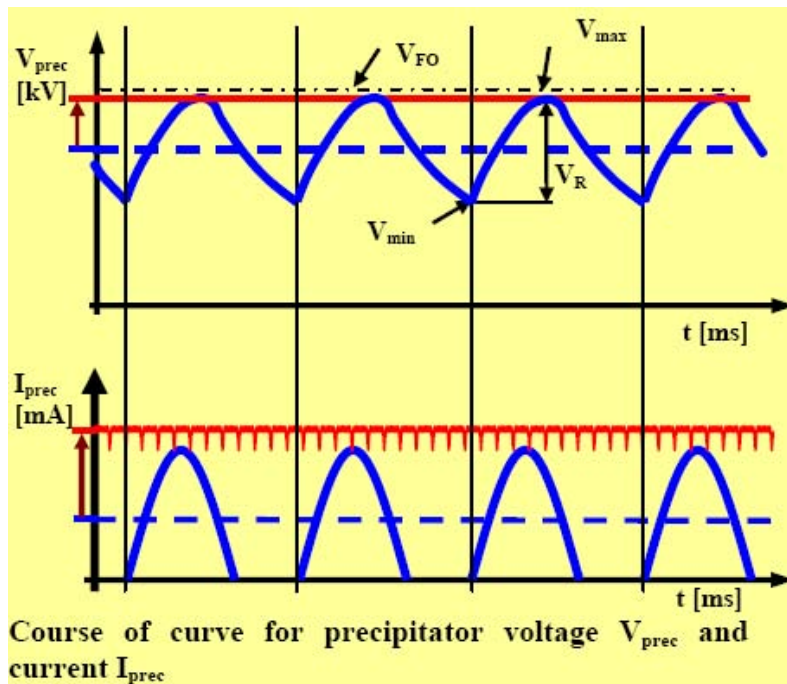

What's The Result? cont.

Conventional

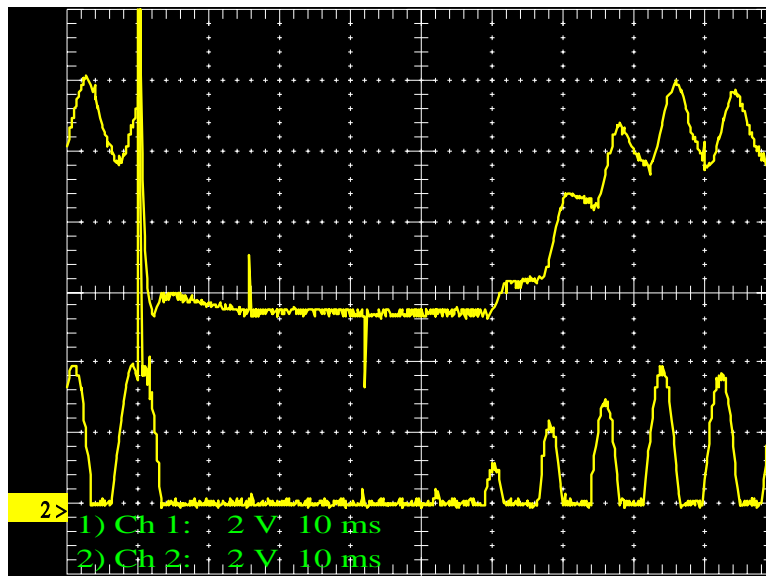

HF

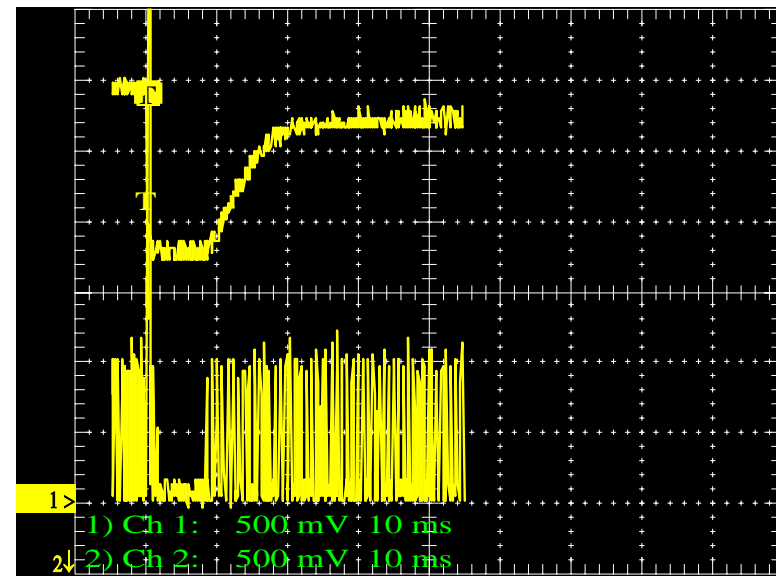

More Power – Improved Performance

What's The Result? cont.



Retrofit



Retrofit

Rebuild/New



we make processes work

What's the Result?

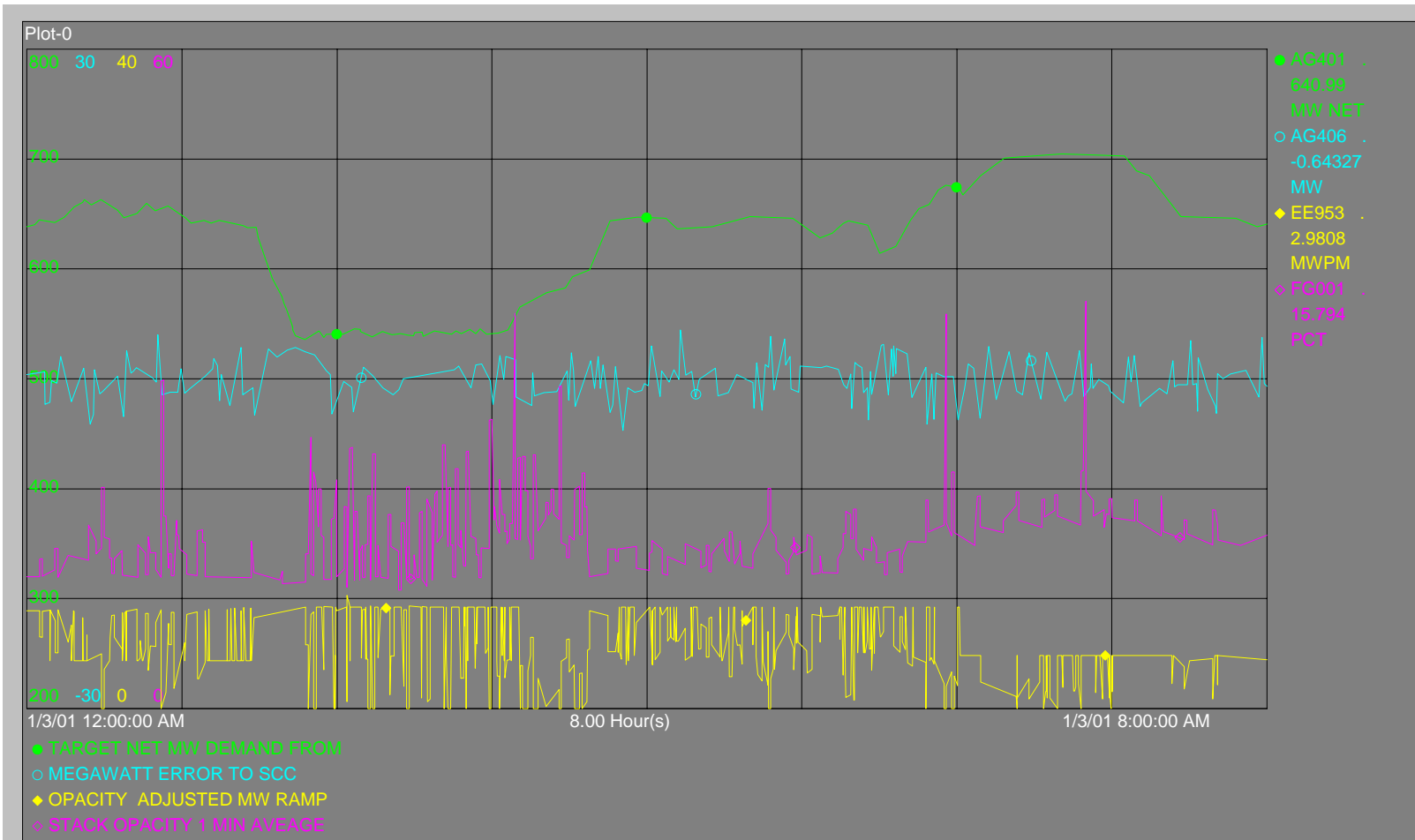

What's the Result?

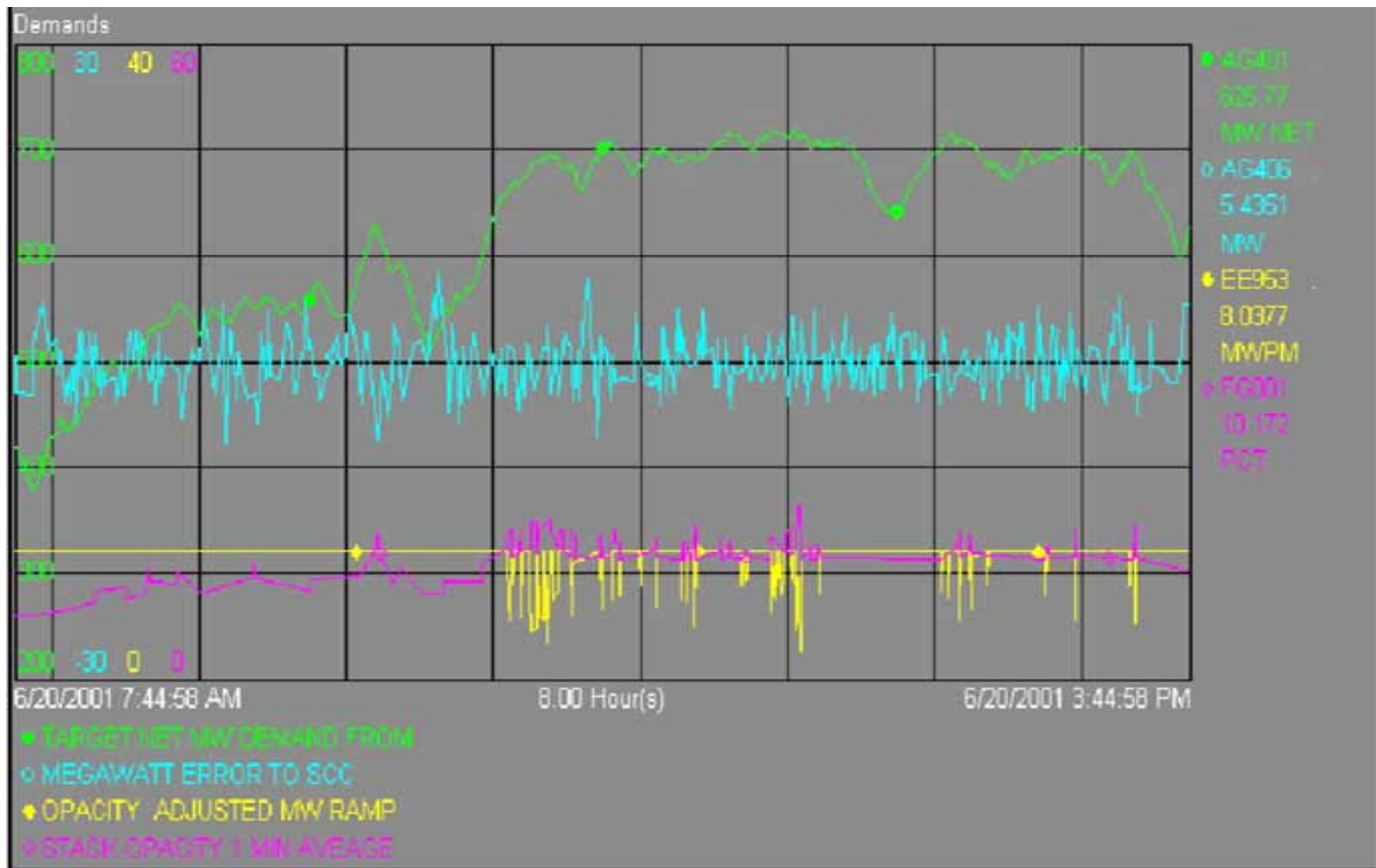

HF History



Good

- Great Increase in Input Power & ESP Performance
- Smaller, Lighter Weight Footprint
- Commercially Acceptable Price Points

Bad

- Typical+ Problems of a New Invention
- Failure Rates of “Scaled up” Units High
- Production Rates Difficult to Maintain as Demand Rose

HF History cont.

Difficult

- Assembly Sub-Suppliers Dictate Parts Availability
- **Component** Sub-Suppliers Arbitrarily Stop Manufacturing
- Market Acceptance is Demanding Output Levels that Available Components Struggle to Support
- Design Changes Required Due to the Above Represent the *Potential* to Repeat the Cycle
- OEM's NOT Calculating Advantages into New ESP Designs

Early Designs

- Small <500 mA
- Cooled by Fluid Circulation or Fans
- High Voltage Transformer Types Varied by Manufacturer

Next Generation – i.e. Present Day



- Outputs Increased to 60/70 kV and 800-1000 mA
- Scaled-up Models Saw Component Stresses Due to Significantly Higher Power
- Component Issues were Managed in IGBT & Diode Areas

Current Installed Base



- Alstom – 1350 Units Worldwide (610 in US)
- NWL – 600th Unit will Ship in '07
- Siemens – 200 Units inc. IGBT Upgrades

What's "New" Now?

NWL

kW	7	21	28	56	70	56	70
kVdc	70	70	70	70	70	83	83
mAdc	100	300	400	800	1000	675	843

kW	105	105	105
kVdc	83	95	70
mAdc	1240	840	1500



What's "New" Now?

Alstom

Rating Introduced

80 kV 250 mA 1993

70 kV 400 mA 1997

70 kV 800 mA 1998

70 kV 1000 mA 1999

70 kV 1700 mA 2006



What's "New" Next?

NWL

<u>kW</u>	<u>kV</u>	<u>mA</u>
105	95	1100
120	95	1250
120	70	1700
120	83	1400



What's “New” Next?

Alstom

Rating Introduced

70 kV 1700 mA 2006

100 kV 1200 mA 2007/2008

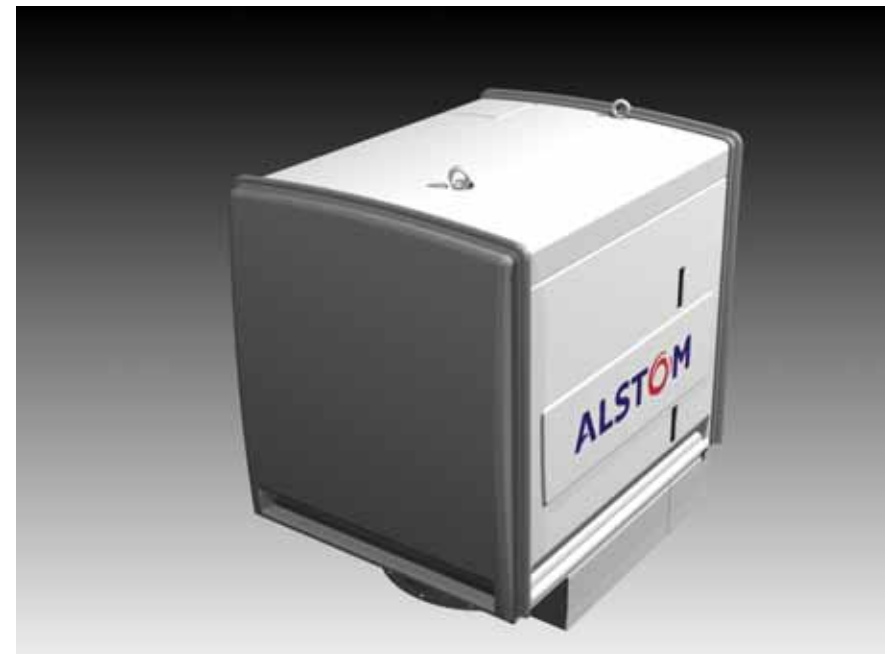

What's “New” to U.S.



Hybrid IGBT Technology

- Used in Conjunction w/Existing TR or New TR
- Existing Cabling Can Be Used
- Current Outputs in Excess of **2500 mA**

What's “New” to U.S.



Thyristor Control



IGBT Conversion

we make processes work

What's “New” to U.S. cont.



Mains voltage 380-500 V – 3 - phase	Type	prec. current (mA _{arithm})	Power (kVA)	Cubicle weight (kg)	Transformer weight (kg)
Type PIC410F <input type="checkbox"/> 90 kV <input type="checkbox"/> 110 kV	PIC90000/600	600	55	280	970
	PIC90000/1500	1500	135	280	1630
	PIC90000/2200	2200	200	280	1630
	PIC110000/500	500	55	280	970
	PIC110000/1500	1500	165	280	1160
	PIC110000/2000	2000	220	280	1330
	PIC110000/2500	2500	275	300	1450

Overall Results



- Performance Improvement Undeniable
- Significant Generation has been Recovered
- TR Mindset Comparisons a Challenge
- Early Reliability Issues Curtailed Acceptance
Roughly 200 Units per Year Over Last Decade
- End-User Demand & Component Issues Result
in Long Lead Times
- Larger Units Will be More Readily Accepted

we make processes work

Thank You!!